

B

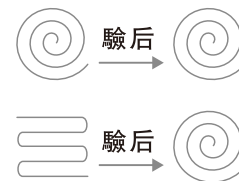
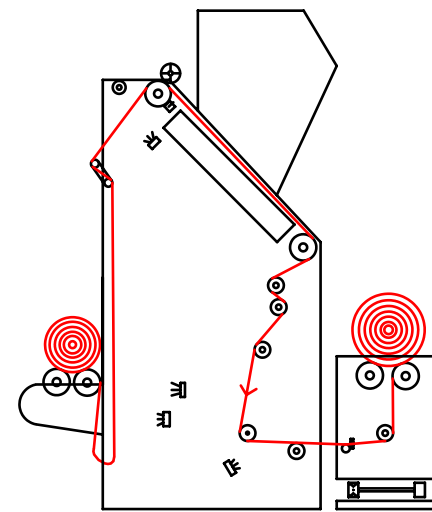

SW-223SRK-ED電腦控制多功能驗布機

COMPUTER-CONTROLLED MULTI-FUNCTIONAL FABRIC INSPECTION MACHINE

功能：驗布、量布、稱重、卷布齊邊、展布邊、電腦張力控制、靜電消除（選裝）
FUNCTIONS: Fabric Inspection, Length Measurement, Weighing, Fabric Rolling Edge Alignment, Spreading Fabric Edge, Computer Control Tension, Static Elimination (Optional)

適用於：針織、梭織、彈性布（通用面料）

BEST FOR: Knit Fabric, Woven, Spandex (General Fabric)

最大卷布直徑：Φ45cm

Maximum Fabric Rolling Diameter: Φ45cm

特點：可根據面料扣分制對面料的疵點項目、疵點位置、疵點原因、扣分數、面料重量、面料長度、面料供應商等資料實時采集并打印，數據存儲并可聯機共享查閱，實現智能化大數據管理。

FEATURES:

The defect types, defect location, defects quantity, defect scores, fabric weight, fabric length and supplier etc. information of the inspected fabric could be recorded, saved to the computer and shared through online computer, and printed out at any time during inspection, so as to achieve big data intelligent management.

耗電量：約2-2.5kw
WATT: 2-2.5kw

有效幅寬：

VALID FABRIC WIDTH:
72" (180cm)
84" (210cm)
94" (235cm)
120" (300cm)

機身尺寸：

SIZE:
242 x 220 x 208 (cm)
273 x 220 x 208 (cm)
298 x 220 x 208 (cm)
365 x 220 x 208 (cm)

(以上產品如有技術、規格、顏色等變動，恕不另行通知，一切實樣按訂貨時為準)
PRODUCT SAMPLE FOR REFERENCE ONLY; ANY ALTERATION IS SUBJECT TO OUR OWN DISCRETION

Http://www.XLFJ.com / www.gjncn.com

E-mail: GJN@XLFJ.com

B

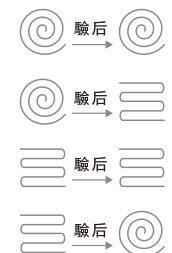
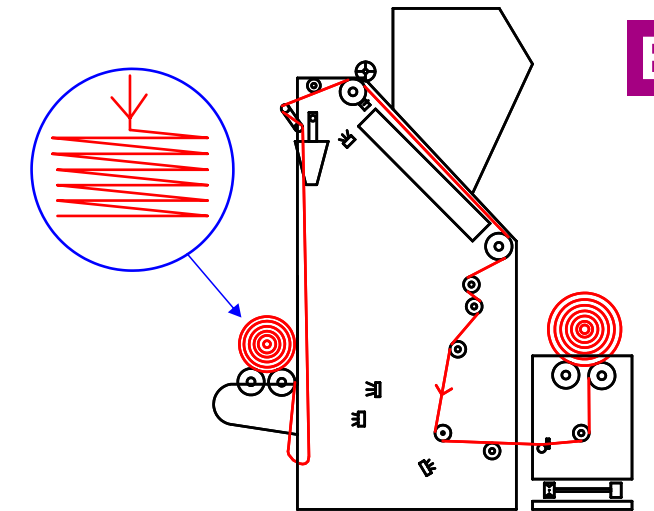

SW-223SRK-ED-LF電腦控制多功能驗布機

COMPUTER-CONTROLLED MULTI-FUNCTIONAL FABRIC INSPECTION MACHINE

功能：驗布、量布、松布、稱重、卷布齊邊、展布邊、電腦張力控制、靜電消除（選裝）
FUNCTIONS: Fabric Inspection, Length Measurement, Fabric Loosening, Weighing, Fabric Rolling Edge Alignment, Spreading Fabric Edge, Computer Control Tension, Static Elimination (Optional)

適用於：針織、梭織、彈性布（通用面料）

BEST FOR: Knit Fabric, Woven, Spandex (General Fabric)

最大卷布直徑：Φ45cm

Maximum Fabric Rolling Diameter: Φ45cm

特點：可根據面料扣分制對面料的疵點項目、疵點位置、疵點原因、扣分數、面料重量、面料長度、面料供應商等資料實時采集并打印，數據存儲并可聯機共享查閱，實現智能化大數據管理。

FEATURES:

The defect types, defect location, defects quantity, defect scores, fabric weight, fabric length and supplier etc. information of the inspected fabric could be recorded, saved to the computer and shared through online computer, and printed out at any time during inspection, so as to achieve big data intelligent management.

耗電量：約2-2.5kw
WATT: 2-2.5kw

有效幅寬：

VALID FABRIC WIDTH:
72" (180cm)
84" (210cm)
94" (235cm)
120" (300cm)

機身尺寸：

SIZE:
242 x 220 x 208 (cm)
273 x 220 x 208 (cm)
298 x 220 x 208 (cm)
365 x 220 x 208 (cm)

(以上產品如有技術、規格、顏色等變動，恕不另行通知，一切實樣按訂貨時為準)
PRODUCT SAMPLE FOR REFERENCE ONLY; ANY ALTERATION IS SUBJECT TO OUR OWN DISCRETION

Http://www.XLFJ.com / www.gjncn.com

E-mail: GJN@XLFJ.com