

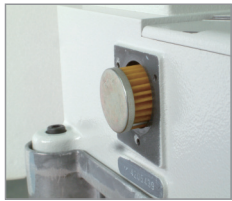

HF008A SERIES FEATURES



HF008A 平台型牛仔用二重環縫紉機 Flat Bed Double Chainstitch Machine for Jeans



精心設計之供油系統及零配件精度加工，延長機器使用壽命

Using unique design of lubrication system and attachments to extend the machine lifetime.

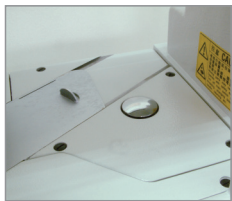

按鈕式縫距調節，可適合多品種生產

Stitch length adjustment by knob, suitable for all different kinds of materials.

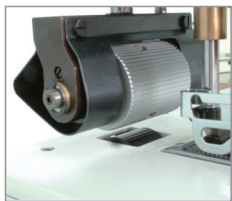

上、下滾輪之雙重配合使出布更順暢

Upper and lower puller design to make sewing process more stable.

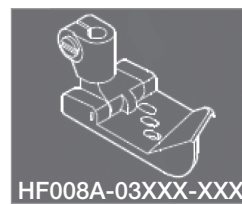

HF008A-03XXX-XXX

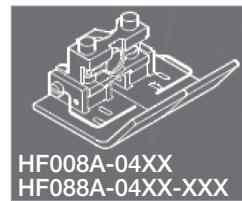
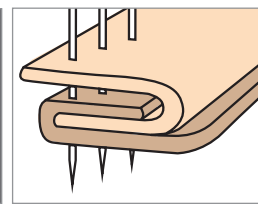

HF008A-04XX
HF008A-04XX-XXX

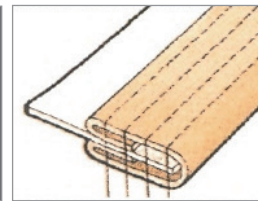

適用工作服、牛仔褲之搭縫(埋夾縫)與褲頭車縫

Suitable for tape binding on waistband of workwear pants, jeans.

H1

	2	4	1/4"(6.4mm)	1.8~3.6	12	UYX128GAS#14~#16	4200	S.P.M. (Max)
HF008A-02064P/HHD	2	4	1/4"(6.4mm)	1.8~3.6	12	UYX128GAS#14~#16	4200	
HF008A-03064P/HHD	3	6	1/4"(6.4mm)	1.8~3.6	12	UYX128GAS#14~#16	4200	

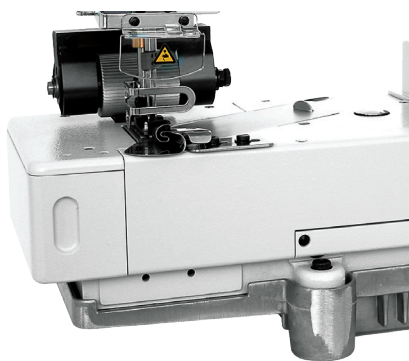

HF008A-02064P/HHD

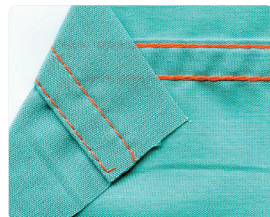
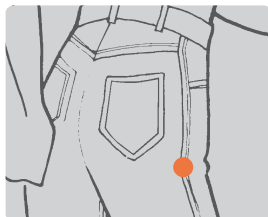

埋夾縫

適用於薄至厚料如工作服、牛仔褲之搭縫。

註：一般出車，均不附喇叭，如有需要可依以上規格訂製

LAP SEAMING

To lap seaming on light to heavy material such as workwears or jeans, etc..

Remark : Folder is not included. Please specify folder no. when ordering.

可選擇之規格 Available Model		布料 Material	喇叭代號 Folder No.
02064/HHD 03064/HHD	1/4"	薄料 light	B511
		中厚料 medium	B511P
		厚料 heavy	B511Q

H2

HF008A-03064P/HTF	3	6	1/4"(6.4mm)	1.8~3.6	12	TVX5 #18~#21	4200	

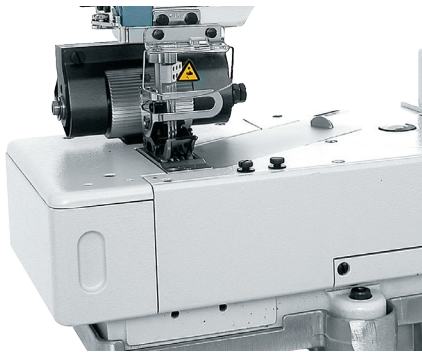

HF008A-03064P/HTF

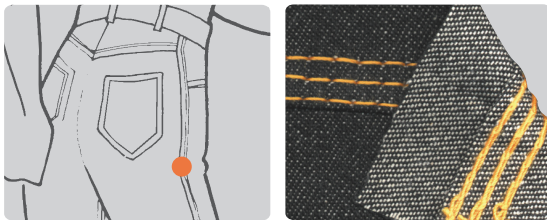

搭縫

適用於中厚布料至極厚布料如工作服、牛仔褲等粗斜紋布之搭縫用。
註：一般出車，均不附喇叭，如有需要可依以上規格訂製

LAP SEAMING

To lap seaming on medium to extra heavy material such as workwears or jeans, etc...

Remark : Folder is not included. Please specify folder no. when ordering.

布料 Material	喇叭代號 Folder No.
中厚料 Medium	B511P
厚料 Heavy	B511Q
極厚料 Extra Heavy	B511R

H3

HF008A-0464-254P/HPR	4	8	1/4-1-1/4" (6.4-25.4-6.4mm)	1.4~3.6	12	TVX5 #18~#21	4500	
HF008A-0664-254P/HPR	4 (6)	8	1/8-1/8-1-1/8-1/8" (3.2-3.2-25.4-3.2-3.2mm)	1.4~3.6	12	TVX5 #18~#21	4500	



HF008A-0664-254P/HPR/B530

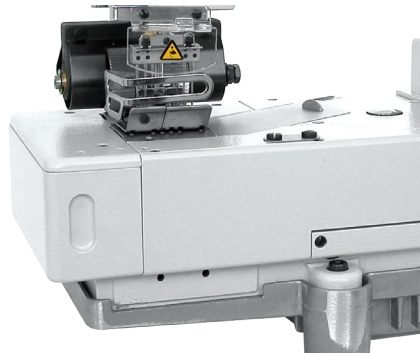

HF008A-0464-254P/HPR

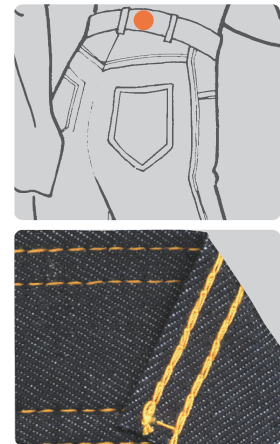

*配備6針規格組，可彈性變換針距
*With 6-needle gauge set for various waistband size

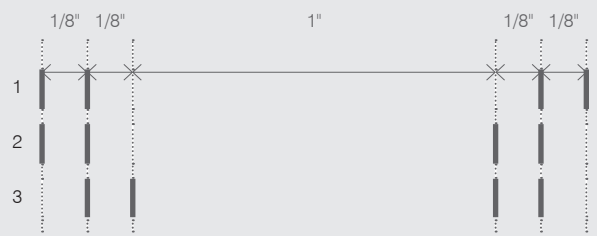

選購配件	OPTIONAL DEVICE
	FH

褲頭上帶滾邊車縫

適用於厚料之工作褲、牛仔褲等褲頭之上帶滾邊一次成型車縫，可依布條之縫合樣式選擇喇叭。

註：一般出車，均不附喇叭，如有需要可依以上規格訂製

WAISTBAND ATTACHING

For tape binding on waistband of workwears pants, jeans...etc. Refer to below table to find optional binders for desirable seams.

Remark : Binder is not included. Please specify binder no. when ordering.



H3

選配喇叭 OPTIONAL BINDER

成品尺寸 (Finished Size)	上下片直送 For Continuous Strips	上下片弧形 For Arched Type	側送喇叭 Side Feeding	前送喇叭 Front Feeding
1" (25mm)	-	-	-	B530
1- 1/8" (29mm)	-	-	-	B530P
1- 1/4" (32mm)	B516	B518	B519	B530Q
1- 3/8" (36mm)	B516P	B518P	B519P	B530R
1- 1/2" (38mm)	B516Q	B518Q	B519Q	B530S
1- 5/8" (42mm)	B516R	B518R	B519R	B530T
1- 3/4" (45mm)	B516S	B518S	B519S	B530U
縫合樣式 Seam Type				

H4

			mm	mm	mm	Needle No.	S.P.M. (Max)
HF008A-0464-254P/PMP	4	8	1/4-1-1/4" (6.4-25.4-6.4mm)	1.4~3.6	12	TVX5 #18~#21	4500
HF008A-0664-254P/PMP	4 (6)	8	1/8-1/8-1-1/8-1/8" (3.2-3.2-25.4-3.2-3.2mm)	1.4~3.6	12	TVX5 #18~#21	4500

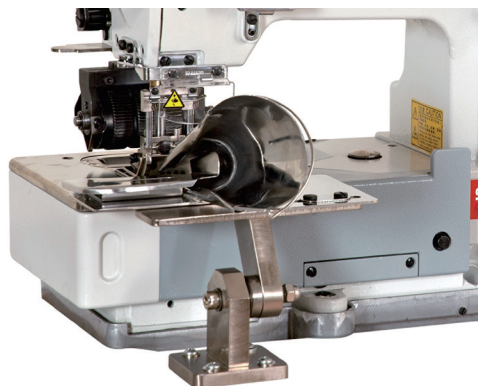

HF008A-0664-254P/PMP/
B530

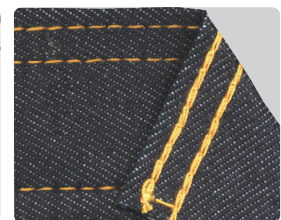
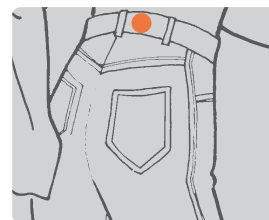

(可調整角度)褲頭上帶滾邊車縫

同HPR褲頭上帶滾邊車縫功能，但角度可進行調整；適用於有曲度之褲腰車縫。

(ANGLE-ADJUSTABLE) WAISTBAND ATTACHING

Same waistband attaching function as HPR, with adjustable angle to process curved workpieces.

H5

HF008A-02056P/FBQ	2	3	7/32"(5.6mm)	1.8~3.6	12	UYX128GAS#10~#11	4200
HF008A-02064P/FBQ	2	3	1/4"(6.4mm)	1.8~3.6	12	UYX128GAS#14~#16	4200

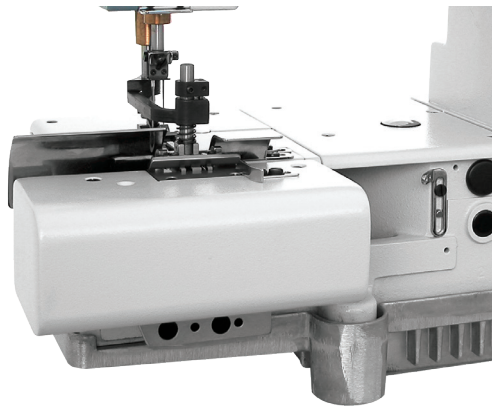

HF008A-02064P/FBQ

褲耳車縫 (附雙邊切刀)

用本輔助件雙邊切刀裁布之功能，可將零碎之廢布利用來製作褲耳，減少布料消耗。

BELT-LOOP SEAMING (WITH RIGHT & LEFT FABRIC TRIMMER)

This machine is equipped with an adjustable fabric trimmer to cut excess fabric edge neatly, and seaming to belt loops for saving cost and increase efficiency.

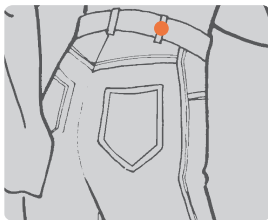

可選擇之規格 Available Model	成品尺寸 Finished Size	喇叭代號 Folder No.	適用 Application
HF008A-02056P/FBQ	9 mm	FBQ14A	男女西褲 Trousers
	10 mm	FBQ14B	
HF008A-02064P/FBQ	12 mm	FBQ14C	牛仔布 Jeans

H6

HF008A-0464-254P/PMP/JD	4	8	1/4-1-1/4" (6.4-25.4-6.4mm)	1.4~3.6	12	TVX5 #18~#21	4500
HF008A-0664-254P/PMP/JD	4 (6)	8	1/8-1/8-1-1/8-1/8" (3.2-3.2-25.4-3.2-3.2mm)	1.4~3.6	12	TVX5 #18~#21	4500



HF008A-0664-254P/PMP/JD



牛仔褲腰車縫 (自動跳針)

車縫褲腰時可使用自動跳針機能避開不需縫製的地方。

JEANS WAISTBAND ATTACHING (WITH SKIP-STITCH FUNCTION)

When sewing waistband at the opening area, skip-stitch function can save your time of cutting the seam.

