

B JN-787SRK-EDS
自動對邊多功能驗布機
(電子張力調校)
MULTIFUNCTIONAL FABRIC
INSPECTION MACHINE WITH AUTO
EDGE ALIGNMENT
(ELECTRONIC TENSION ADJUSTMENT)

JN-786SRK-EDS
自動對邊多功能驗布機
MULTIFUNCTIONAL FABRIC
INSPECTION MACHINE WITH AUTO
EDGE ALIGNMENT

功能：驗布、量布、卷布齊邊、展布邊、張力調校
FEATURES: FABRIC INSPECTION, MEASUREMENT,
FABRIC ROLLING EDGE ALIGNMENT, TENSION
ADJUSTMENT
適用於：針織、梭織、彈性布 (通用面料)
BEST FOR: KNIT FABRIC, WOVEN, SPANDEX
(GENERAL FABRIC)

最大卷布直徑：Φ45cm
MAXIMUM FABRIC ROLLING DIAMETER: Φ45cm
耗電量：約2~2.5Kw
WATT: 2~2.5Kw
有效幅寬： 機身尺寸：
VALID FABRIC WIDTH: SIZE:
72" (180cm) 255 x 147 x 187 (cm)
84" (210cm) 285 x 147 x 187 (cm)
94" (235cm) 310 x 147 x 187 (cm)
120" (300cm) 376 x 147 x 187 (cm)

- 1、可加裝下燈箱角度可調功能 (需另行訂購)
Equipped the function of adjusting the angle of the bottom light(Optional)
- 2、可加裝靜電消除功能 (需另行訂購)
Equipped static elimination function(Optional)
- 3、可加裝稱重工作臺、定長斷布機功能 (需另行訂購)
Equipped weighing working table, end cutter function(Optional)

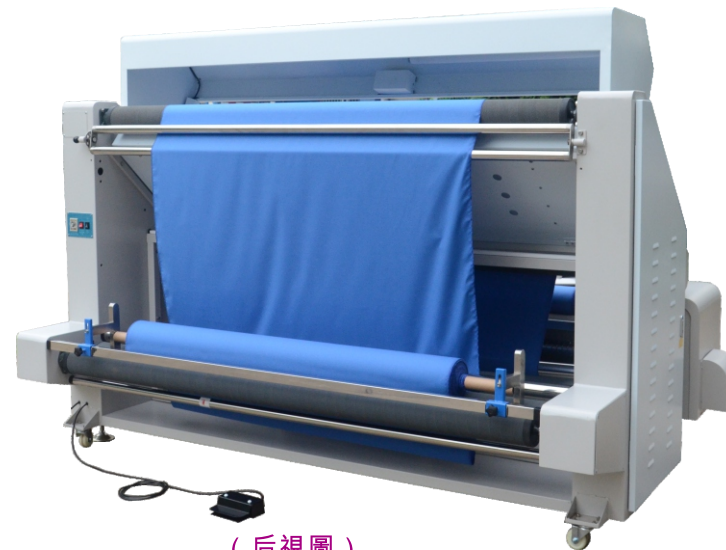
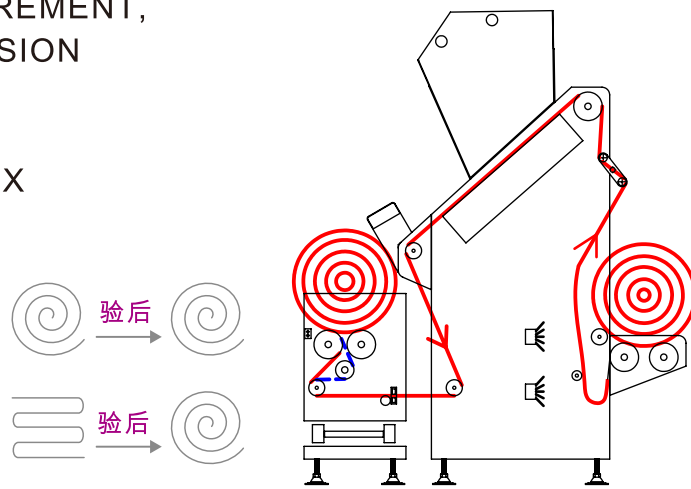
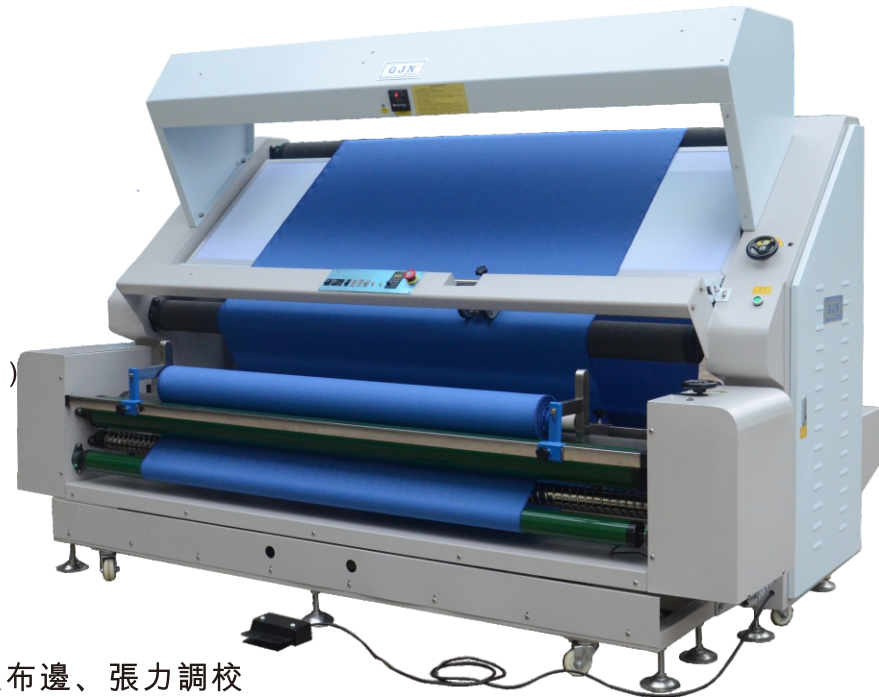

(后視圖)
REAR ELEVATION

(以上產品如有技術、規格、顏色等變動，恕不另行通知，一切實樣按訂貨時為準)
PRODUCT SAMPLE FOR REFERENCE ONLY; ANY ALTERATION IS SUBJECT TO OUR OWN DISCRETION

Http://www.XLFJ.com / www.gjncn.com E-mail:GJN@XLFJ.com

JN-787SRK-ED-LF
自動對邊多功能卷布、驗布、松布機
(電子張力調校)
MULTIFUNCTIONAL FABRIC INSPECTION,
LOOSEING AND ROLLING MACHINE
WITH EGDE ALIGNMENT
(ELECTRONIC TENSION ADJUSTMENT)

JN-786SRK-ED-LF
自動對邊多功能卷布、驗布、松布機
MULTIFUNCTIONAL FABRIC INSPECTION,
LOOSEING AND ROLLING MACHINE
WITH EGDE ALIGNMENT

功能：驗布、量布、卷布齊邊、展布邊、張力調校
FEATURES: FABRIC INSPECTION, MEASUREMENT,
FABRIC ROLLING EDGE ALIGNMENT, TENSION
ADJUSTMENT
適用於：針織、梭織、彈性布 (通用面料)
BEST FOR: KNIT FABRIC, WOVEN, SPANDEX
(GENERAL FABRIC)

最大卷布直徑：Φ45cm
MAXIMUM FABRIC ROLLING DIAMETER: Φ45cm
耗電量：約2~2.5Kw
WATT: 2~2.5Kw
有效幅寬： 機身尺寸：
VALID FABRIC WIDTH: SIZE:
72" (180cm) 255 x 147 x 187 (cm)
84" (210cm) 285 x 147 x 187 (cm)
94" (235cm) 310 x 147 x 187 (cm)
120" (300cm) 376 x 147 x 187 (cm)

- 1、可加裝下燈箱角度可調功能 (需另行訂購)
Equipped the function of adjusting the angle of the bottom light(Optional)
- 2、可加裝靜電消除功能 (需另行訂購)
Equipped static elimination function(Optional)
- 3、可加裝稱重工作臺、定長斷布機功能 (需另行訂購)
Equipped weighing working table, end cutter function(Optional)

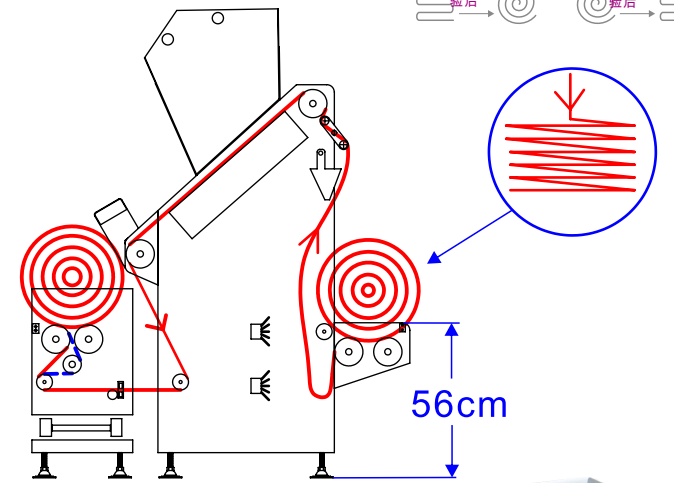

(后視圖 1)
REAR ELEVATION 1

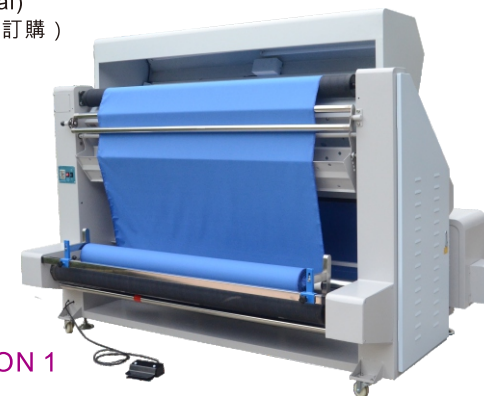

(后視圖 2)
REAR ELEVATION 2

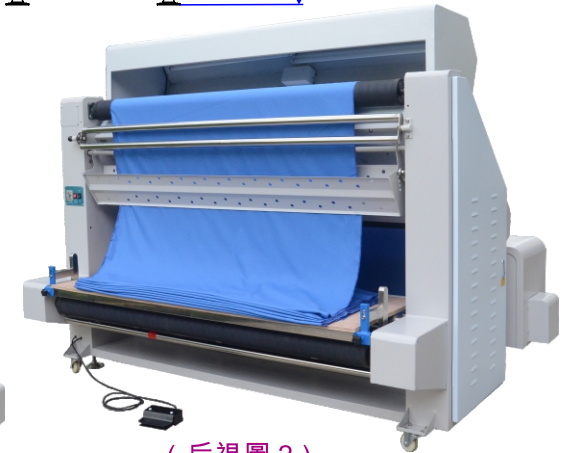

(以上產品如有技術、規格、顏色等變動，恕不另行通知，一切實樣按訂貨時為準)
PRODUCT SAMPLE FOR REFERENCE ONLY; ANY ALTERATION IS SUBJECT TO OUR OWN DISCRETION

Http://www.XLFJ.com / www.gjncn.com E-mail:GJN@XLFJ.com