

B



SW-124SRK-ED-LF-DL

多功能自動對邊卷布、驗布、松布機

MULTIFUNCTIONAL FABRIC INSPECTION, LOOSENING AND ROLLING MACHINE WITH EDGE ALIGNMENT

功能：驗布、量布、鬆布、卷布齊邊、展布邊、張力調校。

FEATURES: FABRIC INSPECTION, FABRIC MEASUREMENT, FABRIC LOOSENING, FABRIC ROLLING AND EDGE ALIGNMENT, TENSION ADJUSTMENT

適用於：針織、梭織、彈性布（通用面料）

BEST FOR: KNIT FABRIC, WOVEN, SPANDEX (GENERAL FABRIC)

最大卷布直徑：Φ100cm

MAXIMUM FABRIC ROLLING DIAMETER: Φ100cm

耗電量：約2-2.5kw

WATT: 2-2.5kw

有效幅寬：

VALID FABRIC WIDTH:

72" (180cm)

84" (210cm)

94" (235cm)

120" (300cm)

機身尺寸：

SIZE: 255 x 310 x 200 (cm)

285 x 310 x 200 (cm)

310 x 310 x 200 (cm)

376 x 310 x 200 (cm)

可加設張力自動控制裝置（需另訂做）

CAN EQUIP TENSION AUTOMATIC CONTROL EQUIPMENT (NEED TO ORDER SEPARATELY)

(后視圖)
REAR ELEVATION



(大卷裝布驗布機)

≤ Φ100cm

BIG ROLL CLOTH INSPECTION MACHINE

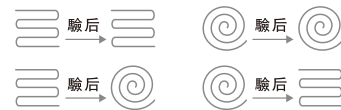

(以上產品如有技術、規格、顏色等變動，恕不另行通知，一切實樣按訂貨時為準)
PRODUCT SAMPLE FOR REFERENCE ONLY; ANY ALTERATION IS SUBJECT TO OUR OWN DISCRETION

Http://www.XLFJ.com / www.gjncn.com

E-mail:GJN@XLFJ.com

B



SW-123SRK-ED-LF

自動對邊多功能卷布、驗布、松布機
(電子張力調校)

MULTIFUNCTIONAL FABRIC INSPECTION, LOOSENING AND ROLLING MACHINE WITH EDGE ALIGNMENT (ELECTRONIC TENSION ADJUSTMENT)

SW-124SRK-ED-LF

自動對邊多功能卷布、驗布、松布機
MULTIFUNCTIONAL FABRIC INSPECTION, LOOSENING AND ROLLING MACHINE WITH EDGE ALIGNMENT

功能：驗布、量布、卷布或鬆布。

FEATURES: FABRIC INSPECTION, MEASUREMENT, ROLLING AND LOOSENING

適用於：針織、梭織布、輕薄高彈針織面料。

BEST FOR: KNIT, WOVEN FABRIC, LIGHTWEIGHT AND HIGH-ELASTIC KNIT FABRIC

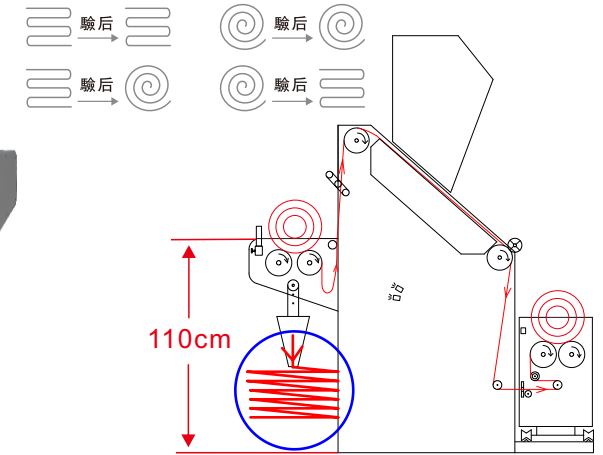

內衣高彈面料首選機型

The first choice of underwear high elastic fabric

最大卷布直徑：Φ45cm

MAXIMUM FABRIC ROLLING DIAMETER: Φ45cm

耗電量：約1.5-2KW

WATT: 1.5-2KW

有效幅寬：

VALID FABRIC WIDTH:

72" (180cm)

84" (210cm)

94" (235cm)

120" (300cm)

機身尺寸：

SIZE:

255 x 155 x 187 (cm)

285 x 155 x 187 (cm)

310 x 155 x 187 (cm)

376 x 155 x 187 (cm)



(后視圖)
REAR ELEVATION



SW-124SR-K普通針、梭織前、后卷驗布機
KNIT FABRIC, WOVEN FORWARD AND BACKWARD FABRIC INSPECTION MACHINE

功能：驗布、量布、前卷、後卷及張力調校

FEATURES: FABRIC INSPECTION, MEASUREMENT, FORWARD, BACKWARD AND TENSION ADJUSTMENT

適用於：梭織、一般彈性針織布料等。

BEST FOR: WOVEN/KNITTED, SPANDEX (GENERAL FABRIC)

最大卷布直徑：Φ45cm

MAXIMUM FABRIC ROLLING DIAMETER: Φ45cm

有效幅寬：

VALID FABRIC WIDTH:

72" (180cm)

84" (210cm)

94" (235cm)

120" (300cm)

機身尺寸：

SIZE:

230 x 125 x 174 (cm)

260 x 125 x 174 (cm)

284 x 125 x 174 (cm)

350 x 125 x 174 (cm)

耗電量：約0.8-1.5KW

WATT: 0.8-1.5KW

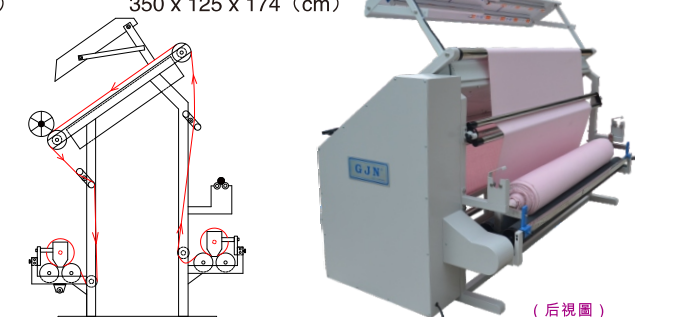

(后視圖)
REAR ELEVATION

(以上產品如有技術、規格、顏色等變動，恕不另行通知，一切實樣按訂貨時為準)
PRODUCT SAMPLE FOR REFERENCE ONLY; ANY ALTERATION IS SUBJECT TO OUR OWN DISCRETION

Http://www.XLFJ.com / www.gjncn.com

E-mail:GJN@XLFJ.com