



DOUBLE CHAINSTITCH MACHINE

VC008A - 04 064 P / VCE

針數
Needle Numbers

後拉引滾輪
Rear Pullers

配件
Device

機種別 Model

VC008A 筒形多針縫紉機(高貫穿力型)
Multineedle Cylinder Bed Double Chainstitch Machine (High Penetration Power Type)

VC008B 筒形多針縫紉機(4~6針高速型)
Multineedle Cylinder Bed Double Chainstitch Machine (4~6 Needles High Speed Type)

HF008A 平台型牛仔用二重環縫紉機
Flat Bed Double Chainstitch Machine for Jeans

NC008 針送牛仔褲腰車
Needle-Feed Cylinder Bed Double Chainstitch Machine for Jeans Waistband

等距針距 Equal Distance Between Needles

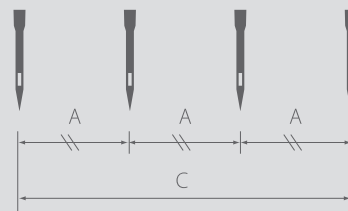

不等距 Unequal Distance Between Needles

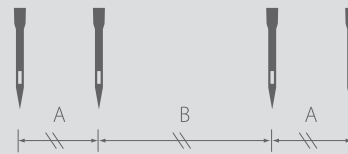

DOUBLE CHAINSTITCH DD SERVO MOTOR

VC008A - 04085P / VWLB / FH / DV□□

DV□□ VC008A/B, HF008A, NC008型直驅電控組
Direct-Drive Servo Motor for VC008A/B, HF008A, NC008

VC008A / B SERIES FEATURES

VC008A

筒型多針縫紉機(高貫穿力型)

Multineedle Cylinder Bed Double Chainstitch Machine (High Penetration Power Type)

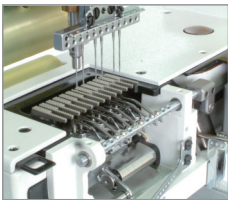
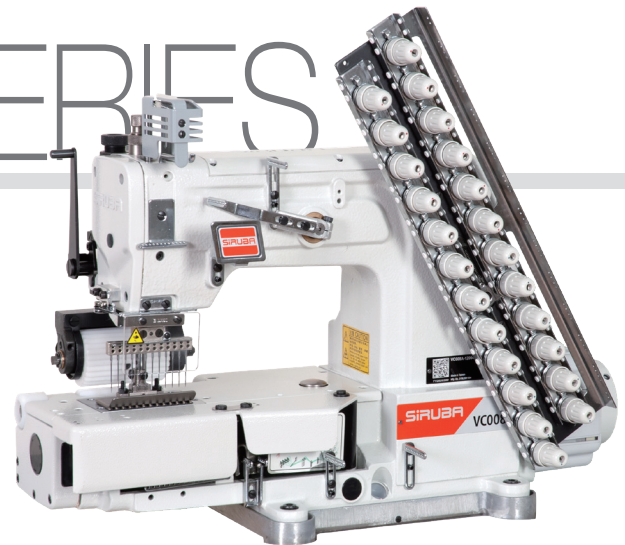

完全自動供油，勾針縱向運動機構，多針雙重鏈式縫

Automatic lubrication system, vertical looper mechanism, multineedle chainstitch mechanism.

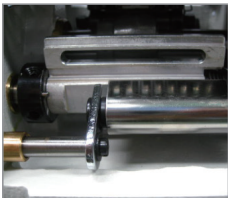

採用獨立勾針座，可變化不同的針位元組合，達到一機多用的功能（選配）

Using independent looper holder and can easily change different needle position, Multi-function machine design.(optional)

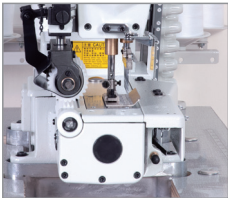

筒型機身設計，方便環型衣物縫紉

Cylinder machine frame design, easy sewing operation for circular cloth.



按鈕式縫距調整模式，調整簡便快速

Stitch length adjustment by knob, easy and fast.

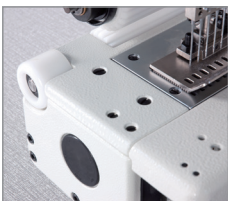

左側附一輔助設計，拉布穩定，出布更順暢，維護便利

Using one supportive puller on left side which can stabilize the pulling and sewing process.

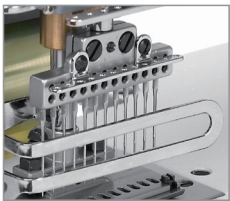

適用於多種工序的縫紉，適合針織類高級衣物之裝飾車縫

Suitable for multi sewing process, high quality knit material and decorative sewing.

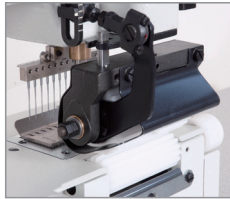
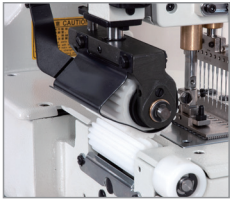

新型軸承式滾輪，縫製時拉布與出布更順暢穩定

New bearing type rear puller handles the material with better stability.

VC008B

筒型多針縫紉機 (4~6針高速型)

Multineedle Cylinder Bed Double Chainstitch Machine (4~6 Needles High Speed Type)

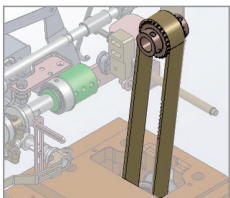

使用皮帶傳動來驅動上下軸，實現高速穩定的縫製

New mechanism uses the belt to drive both upper and lower shaft, provides faster and more stable sewing experience.

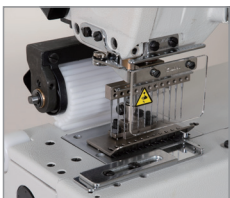

平順且低振動，車縫薄料得心應手

High performance with thin material, less vibration and smoother movement.

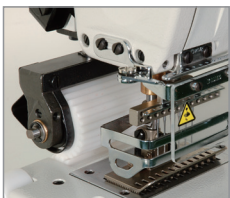

新型軸承式滾輪，縫製時拉布與出布更順暢穩定

New bearing type rear puller handles the material with better stability.



 mm	1.4-3.6	 mm	12	 Needle No.	UOX113GS #11~#14	 S.P.M. (Max)	4500
--	---------	--	----	--	---------------------	---	------

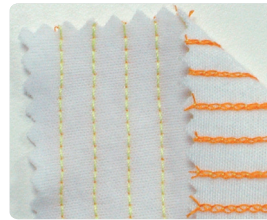
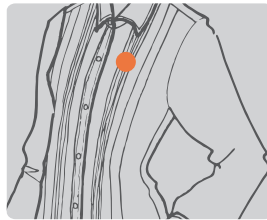

4針機型

4-Needle type

VC008A-04XXX
VC008A-04XXX-XXX

12針機型

12-Needle type

VC008A-12XXX
VC008A-12XXX-XXX
VC008A-13XXX
VC008A-13XXX-XXX
VC008A-17XXX
VC008A-21XXX
VC008A-23XXX







一般平縫

完全自動給油·勾針縱向運動機構·筒型車台·利於圓筒型衣物之縫紉·適用於一般高級衣物之裝飾車縫。

GENERAL SEAMING

Cylinder bed automatic oiling, back and forth loopers driving mechanism, suitable for decorative sewing on high quality dress or tubular goods.

V2

Model	Specification			 mm	 mm	2.5-5	 mm	12	Needle No.	UOX113GS #11~#14	 S.P.M. (Max)	4000	Remark				
														每單位 (Unit)=1.6mm=1/16"			
26 24 22 20 18 16 14 12 10 8 6 4 2 2 4 6 8 10 12 14 16 18 20 22 24 26																	
VC008A-	1132-064P	11	22	(1/8-1/4-1/8") (3.2-6.4-3.2mm)													

[三合一] 褲頭車縫

本機型適用鬆緊帶皺褶型、平坦型、薄牛仔·可以彈性組合出各種常用的4針針位組如1/4-1/4-1/4, 1/4-3/4-1/4...等。



[3 in 1] WAIST BAND SEWING

This model is applicable to elastic band wrinkled type, flat type, light denim, which offers various 4-needle gauges by one set.
E.g.: 1/4-1/4-1/4, 1/4-3/4-1/4...etc.





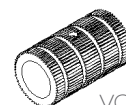

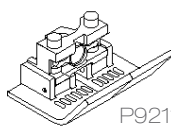

選購配件 OPTIONAL DEVICE

VCE

 VCL08S	細齒上拉輪 (鋼質)·薄牛仔 Fine teeth type upper puller (steel).light denim.
 VCL16P  VCL28	平輪組 (PU 材質) Flat type puller set (PU)
 P9211A-A	二段式壓腳 Two-piece type presser foot

V3

							Needle No.	
VC008A- VC008B-	04064P/VCE	4	8	1/4"(6.4mm)	1.4~3.6	12	UOX113GS #11~#14	4000
	04085P/VCE	4	8	1/3"(8.5mm)	1.4~3.6	12	UOX113GS #11~#14	4000
	04095P/VCE	4	8	3/8"(9.5mm)	1.4~3.6	12	UOX113GS #11~#14	4000
	04106P/VCE	4	8	5/12"(10.6mm)	1.4~3.6	12	UOX113GS #11~#14	4000
	04127P/VCE	4	8	1/2"(12.7mm)	1.4~3.6	12	UOX113GS #11~#14	4000

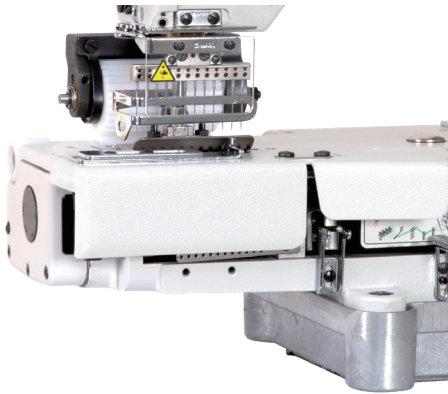

VC008B-04064P/VCE

褲頭鬆緊帶車縫

用於運動褲或運動短褲等圓筒型衣褲腰部鬆緊帶的包縫，本機型可有兩種縫合的方式：
(1)環型鬆緊帶布料折邊縫 (2)拷克後上環型鬆緊帶包縫

ELASTIC INSERTING / ATTACHING





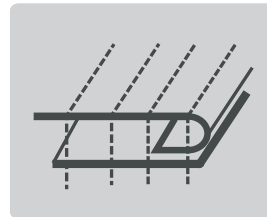
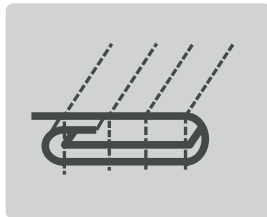

Inserting and attaching elastic on waistband of jogging suits, sportswears or shirts etc., two types of sewing functions are available :

1. To attach tubular seamless elastic waistband.
2. To cover sewing on elastic after overlock seaming.

選購配件 OPTIONAL DEVICE
VAD , RL



V4

							Needle No.	
VC008A-	04064P/VWL	4	8	1/4"(6.4mm)	1.4~3.6	12	UOX113GS #11~#14	4000
	04085P/VWL	4	8	1/3"(8.5mm)	1.4~3.6	12	UOX113GS #11~#14	4000
	04095P/VWL	4	8	3/8"(9.5mm)	1.4~3.6	12	UOX113GS #11~#14	4000
	04106P/VWL	4	8	5/12"(10.6mm)	1.4~3.6	12	UOX113GS #11~#14	4000
	04127P/VWL	4	8	1/2"(12.7mm)	1.4~3.6	12	UOX113GS #11~#14	4000

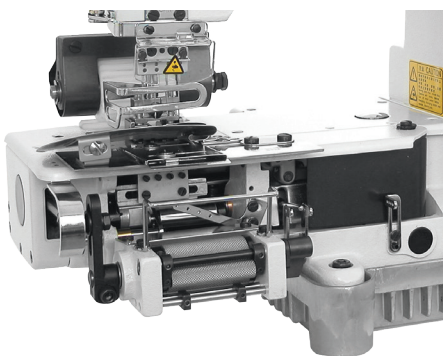

VC008A-04085P/VWL

選購配件 OPTIONAL DEVICE
FH

褲頭鬆緊帶車縫 (附B413喇叭)

鬆緊帶送帶滾輪裝置能依據機台之運轉速度送帶，可準確控制鬆緊帶長度與鬆緊度，操作簡便，適用於慢跑褲、運動褲、男女內褲等褲頭之鬆緊帶車縫。

註：B413喇叭可用鬆緊帶尺寸為 38mm

ELASTIC ATTACHING (WITH FOLDER B413)

Elasticity and length feeding can be accurately controlled according to sewing speed of machine. Easy operation for elastic inserting and attaching on waistband of jogging pants, sportswears, briefs etc.

Remark : Elastic size 38mm for folder B413

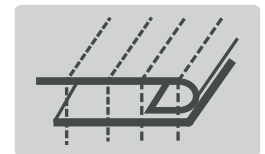



V5

							Needle No.	
VC008A-	04064P/VWLB	4	8	1/4"(6.4mm)	1.4~3.6	12	UOX113GS #11~#14	4000
	04085P/VWLB	4	8	1/3"(8.5mm)	1.4~3.6	12	UOX113GS #11~#14	4000
	04095P/VWLB	4	8	3/8"(9.5mm)	1.4~3.6	12	UOX113GS #11~#14	4000
	04106P/VWLB	4	8	5/12"(10.6mm)	1.4~3.6	12	UOX113GS #11~#14	4000
	04127P/VWLB	4	8	1/2"(12.7mm)	1.4~3.6	12	UOX113GS #11~#14	4000

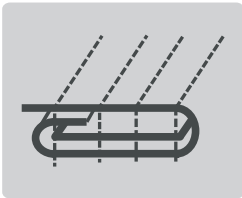

褲頭鬆緊帶車縫 (附B411喇叭及撐開滾輪組)

鬆緊帶送帶滾輪裝置能依據機台之運轉速度送帶，可準確控制鬆緊帶長度與鬆緊度，操作簡便，適用於慢跑褲、運動褲、男女內褲等褲頭之鬆緊帶車縫。

喇叭尺寸 Folder Size	成品尺寸 Finished Size	鬆緊帶尺寸 Elastic Tape Size	適用機型 Applicable Model
B411	33 mm	31 mm	04095
B411P	30 mm	28 mm	04085
B411Q	42 mm	40 mm	04127
B411R	25 mm	23 mm	04064
B411S	36 mm	34 mm	04106

ELASTIC INSERTING (WITH FOLDER B411 AND EXTENDING ROLLER)

Elasticity and length feeding can be accurately controlled according to sewing speed of machine. Easy operation for elastic inserting and attaching on waistband of jogging pants, sportswears, briefs etc.

選購配件 OPTIONAL DEVICE
FH

V6

							Needle No.	
VC008A-	04064P/VWLC	4	8	1/4"(6.4mm)	1.4~3.6	12	UOX113GS #11~#14	4000
	04085P/VWLC	4	8	1/3"(8.5mm)	1.4~3.6	12	UOX113GS #11~#14	4000
	04095P/VWLC	4	8	3/8"(9.5mm)	1.4~3.6	12	UOX113GS #11~#14	4000
	04106P/VWLC	4	8	5/12"(10.6mm)	1.4~3.6	12	UOX113GS #11~#14	4000
	04127P/VWLC	4	8	1/2"(12.7mm)	1.4~3.6	12	UOX113GS #11~#14	4000
	12048P/VWLC	12	24	3/16"(4.8mm)	1.4~3.6	12	UOX113GS #11~#14	4000
	12064P/VWLC	12	24	1/4"(6.4mm)	1.4~3.6	12	UOX113GS #11~#14	4000

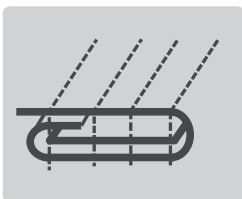

褲頭鬆緊帶車縫 (附VCE導片)

鬆緊帶送帶滾輪裝置能依據機台之運轉速度送帶，可準確控制鬆緊帶長度與鬆緊度，操作簡便，適用於慢跑褲、運動褲、男女內褲等褲頭之鬆緊帶車縫。

ELASTIC INSERTING /ATTACHING (WITH VCE FABRIC GUIDE)

Elasticity and length feeding can be accurately controlled according to sewing speed of machine. Easy operation for elastic inserting and attaching on waistband of jogging pants, sportswears, briefs etc.

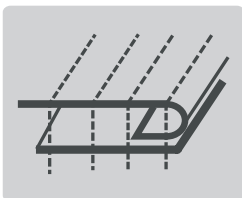

選購配件 OPTIONAL DEVICE
FH

V7

		mm	mm	mm	mm	mm	Needle No.	S.P.M. (Max)
VC008A-06048P/VPL	06048P/VPL	6	12	3/16"(4.8mm)	1.4~3.6	12	UOX113GS #11~#14	4000
VC008B-06064P/VPL	06064P/VPL	6	12	1/4"(6.4mm)	1.4~3.6	12	UOX113GS #11~#14	4000



VC008B-06064P/VPL

上帶車縫

適用於裝飾條帶、運動衣褲等車縫，效率高、品質穩定。

TAPE ATTACHING

Suitable for attaching ornament tape on sportswears.
For high efficiency and perfect quality sewing.

選購配件 OPTIONAL DEVICE

LSA

若需要更高階機型，請參考
ASV-ATS100A (P.16)
For advanced model, please
refer to ASV-ATS100 (P.16)

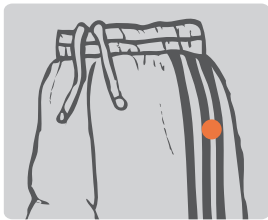
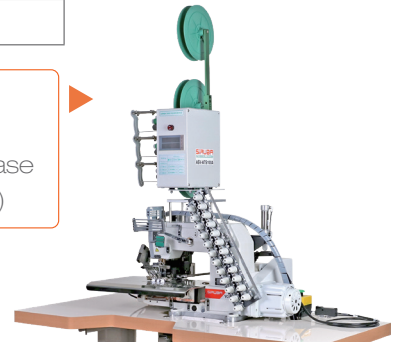

V8

		mm	mm	mm	mm	mm	Needle No.	S.P.M. (Max)
VC008A-12048P/VPQ	12048P/VPQ	12	24	3/16"(4.8mm)	1.4~3.6	12	UOX113GS #11~#14	4000
VC008A-12064P/VPQ	12064P/VPQ	12	24	1/4"(6.4mm)	1.4~3.6	12	UOX113GS #11~#14	4000

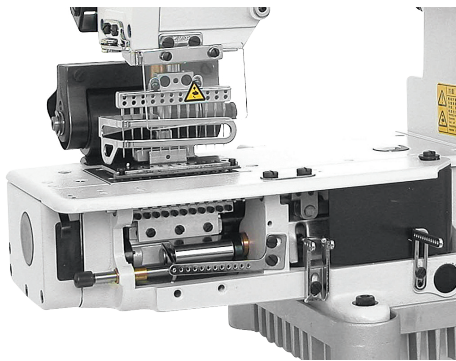

VC008A-12064P/VPQ

鬆緊帶抽皺縫裝置

適用於女皺折連身衣裙等腰邊鬆緊線皺折，如女用襯衫，游泳衣，枕頭套，兒童衫等
均能車縫順暢。

注：勾針底線宜用彈性線

ELASTIC THREAD SHIRRING SEWING

Suitable for sewing ornamental shirring with elastic thread on women's blouses, swimsuits, dresses, pillowcases, and children's shirts etc.
Remark : Suggested to use elastic thread for lower looper

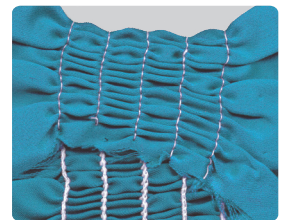
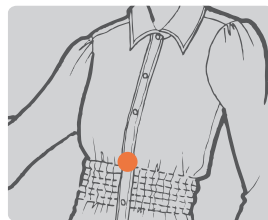



V9

				mm	mm		Needle No.	S.P.M. (Max)
VC008A-	12048P/VPQ-K	12	24	3/16"(4.8mm)	1.4~3.6	12	UOX113GS #11~#14	4000
	12064P/VPQ-K	12	24	1/4"(6.4mm)	1.4~3.6	12	UOX113GS #11~#14	4000

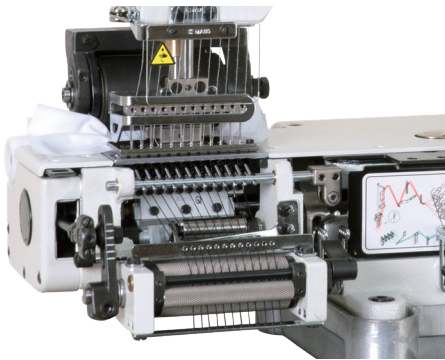

VC008A-12048P/VPQ-K

鬆緊帶抽皺縫裝置

適用於女皺褶連身衣裙等腰邊鬆緊線皺褶，如女用襯衫、游泳衣、枕頭套、兒童衫等均能車縫順暢。

註：

1. 勾針底線宜用彈性線
2. 增加VWL組可穩定彈性線的鬆緊度讓車縫更平順美觀，不跳針
3. 將彈性線安裝於桌板下，讓彈性線車縫更順暢
4. 本機為多功能車，可調為VWL、VPQ或一般車使用

ELASTIC THREAD SHIRRING SEWING

Suitable for sewing ornamental shirring with elastic thread on women's blouses, swimsuits, dresses, pillowcases, and children's shirts etc.

Remark :

1. Suggested to use elastic thread for lower looper.
2. The added VWL set will further stabilize the tension of elastic thread and make sewing process more smoothly, also can avoid stitch skipping.
3. Holds the elastic thread under the table to make sewing process more smoothly.
4. This is a multifunctional machine, can easily adjust to VWL, VPQ, or standard machine.

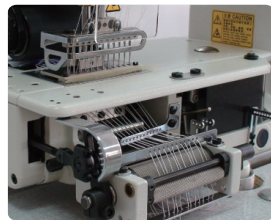
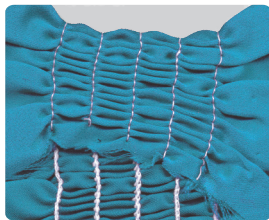
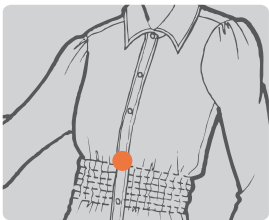

V10

				mm	mm		Needle No.	S.P.M. (Max)
VC008A-	12048P/VPS	12	12	3/16"(4.8mm)	1.4~3.6	12	DV-K25 #18~21	4000
	12064P/VPS	12	12	1/4"(6.4mm)	1.4~3.6	12	DV-K25 #18~21	4000

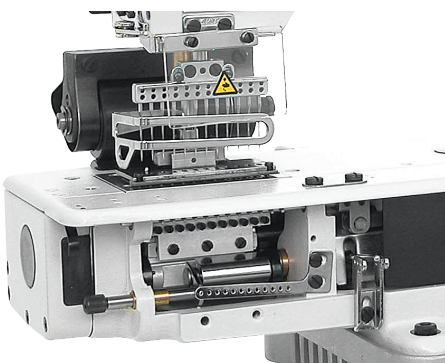

VC008A-12064P/VPS

鬆緊帶抽皺縫裝置

適用於女皺褶連身衣裙等腰邊鬆緊線皺褶，如女用襯衫、游泳衣、枕頭套、兒童衫等均能車縫順暢。

註：針線用彈性線，以勾針為勾線功能不穿線，為101車縫式樣

ELASTIC THREAD SHIRRING SEWING

Suitable for sewing ornamental shirring with elastic thread on women's blouses, swimsuits, dresses, pillowcases, and children's shirts etc.

Remark : Needle uses elastic thread and looper without thread. It's 101 sewing type.

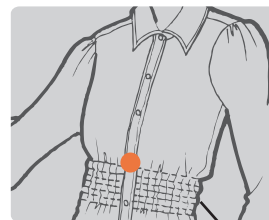

V11

							Needle No.	
VC008A-	04A64-191P/VSF	4	8	1/4-3/4-1/4" (6.4-19.1-6.4mm)	1.4~3.6	12	UOX113GS #11~#14	4000
	04A64-254P/VSF	4	8	1/4-1-1/4" (6.4-25.4-6.4mm)	1.4~3.6	12	UOX113GS #11~#14	4000

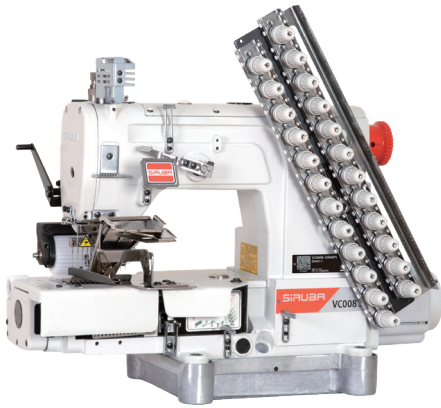

VC008A-04A64-254P/VSF

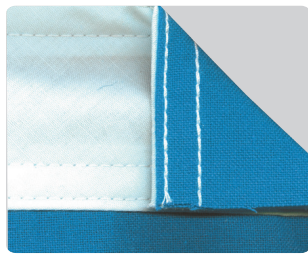
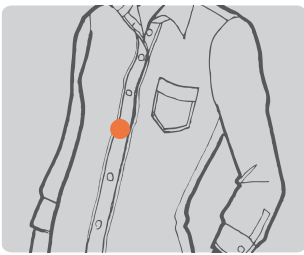

襯衫門襟車縫

適宜各種四針或二針之襯衫門襟車縫，由於加裝喇叭使在一個工序即可完成車縫，另可選擇不同的喇叭做不同之車縫樣式。

SHIRT-FRONTING ATTACHING

With a special folder to sew on 2 or 4 needled shirt fronting, complete in one simple sewing operation. Also available are the various folders for different sewing style.

選購配件	OPTIONAL DEVICE
LSA	

V12

							Needle No.	
VC008A-	12048P/VSC	12	36	3/16"(4.8mm)	1.4~3.6	12	UOX113GS #11~#14	2500
	12064P/VSC	12	36	1/4"(6.4mm)	1.4~3.6	12	UOX113GS #11~#14	2500

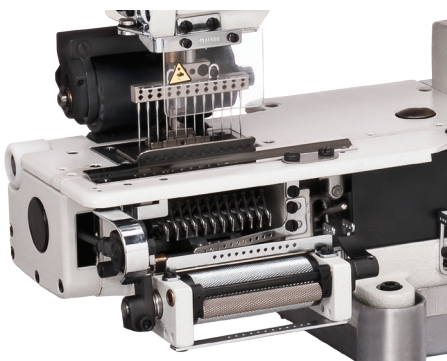

VC008A-12064P/VSC

鬆緊帶抽皺縫裝置

彈性線直送不打線圈，由針線與勾針線上下包覆，車縫成品效果較VPQ薄，且皺褶可拉伸至完全平坦。

ELASTIC THREAD SHIRRING SEWING

Elastic thread is straight, not looped, which is fixed by needle thread and looper thread. The finish is thinner than VPQ and the shirring becomes flat as it is pulled extensively.

