

B

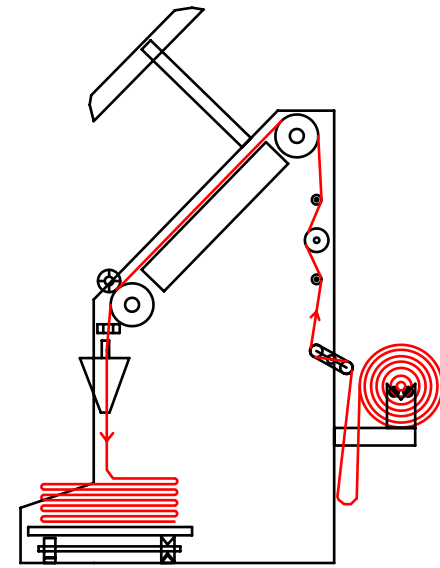
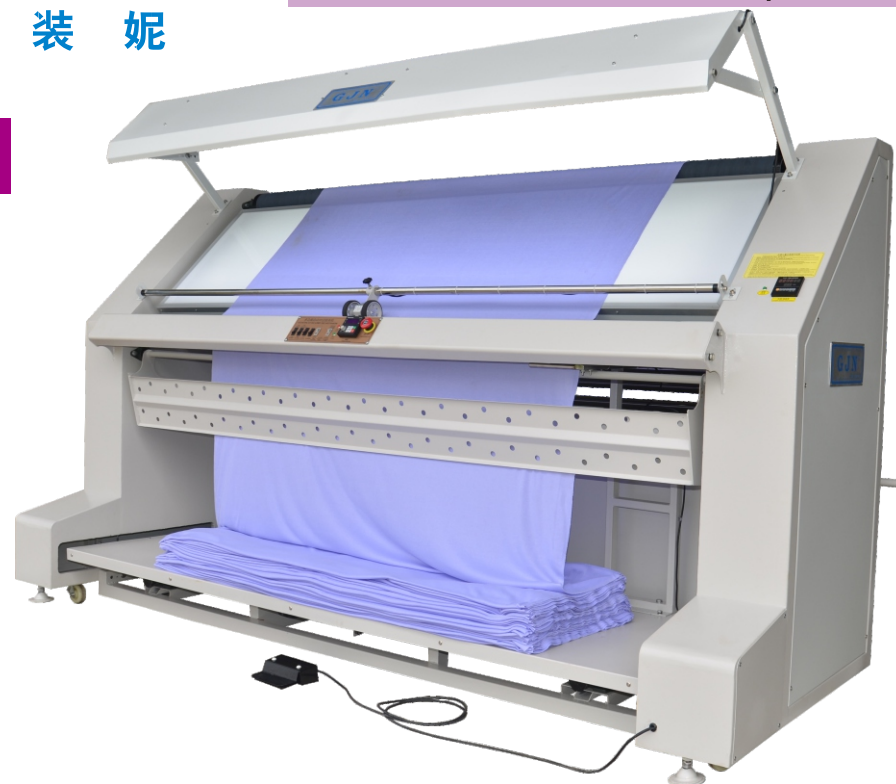

JN-786LF-ED自動對邊松(疊)布、驗布機
AUTO EDGE ALIGNMENT FABRIC LOOSENING
(FOLDING) AND INSPECTION MACHICE

功能： 驗布、量布、鬆(疊)布齊邊

FEATURES: FABRIC INSPECTION, FABRIC MEASUREMENT, FABRIC LOOSENING (FOLDING) AND EDGE ALIGNMENT

適用於： 針織、梭織、彈性布(通用面料)

BEST FOR: KNIT FABRIC, WOVEN, SPANDEX (GENERAL FABRIC)

最大卷布直徑： Φ45cm

MAXIMUM FABRIC ROLLING DIAMETER: Φ45cm

耗電量：

WATT: 1.6-1.85kw

有效幅寬：

VALID FABRIC WIDTH:

72" (180cm)

84" (210cm)

94" (235cm)

機身尺寸：

SIZE:

243 x 180 x 200 (cm)

273 x 180 x 200 (cm)

298 x 180 x 200 (cm)

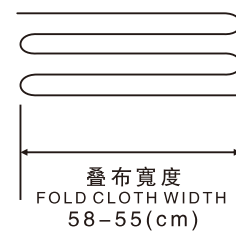

(后視圖)
REAR ELEVATION

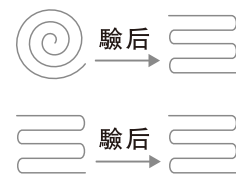

(以上產品如有技術、規格、顏色等變動，恕不另行通知，一切實樣按訂貨時為準)
PRODUCT SAMPLE FOR REFERENCE ONLY; ANY ALTERATION IS SUBJECT TO OUR OWN DISCRETION

Http://www.XLFJ.com / www.gjncn.com

E-mail:GJN@XLFJ.com

B

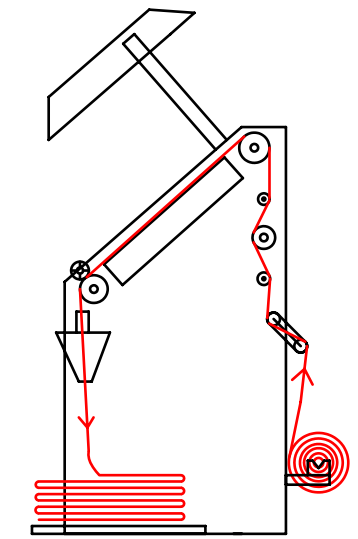

JN-786LF 針織驗布、松布機
KNIT FABRIC INSPECTION AND
FABRIC LOOSENING MACHINE

功能： 驗布、量布、鬆布。

FEATURES: FABRIC INSPECTION, MEASUREMENT, LOOSENING

適用於： 針織、彈性布、梭織布等

BESTFOR: KNIT, SPANDEX, WOVEN FABRIC

最大卷布直徑： Φ45cm

MAXIMUM FABRIC ROLLING DIAMETER: Φ45cm

耗電量： WATT 1.8kw

有效幅寬：

VALID FABRIC WIDTH:

72" (180cm)

84" (210cm)

94" (235cm)

機身尺寸：

SIZE:

243 x 130 x 205 (cm)

273 x 130 x 205 (cm)

298 x 130 x 205 (cm)

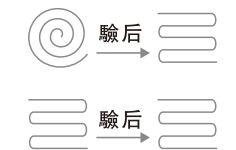

(后視圖)
REAR ELEVATION



(以上產品如有技術、規格、顏色等變動，恕不另行通知，一切實樣按訂貨時為準)
PRODUCT SAMPLE FOR REFERENCE ONLY; ANY ALTERATION IS SUBJECT TO OUR OWN DISCRETION

Http://www.XLFJ.com / www.gjncn.com

E-mail:GJN@XLFJ.com